

## High performance digital counter/length counter T6GC/T6DC/T6FC

Technical Manual

Version number: EN-V1-01



Thank you very much for choosing TMCON products,  
In order to better use this product, please read the following before using.

## ■ Safety precautions

---

### Attention

Do not touch the terminals while power is on, otherwise minor injuries may occur due to electric shock.



Do not allow metal objects, conductors, debris (such as cuttings) from installation work, moisture, or other foreign matter to enter the digital controller, the setup tool ports, or between the pins on the connectors on the Setup Tool cable. Otherwise it may cause electric shock, short circuit or machine malfunction.



Do not use the product where subject to flammable or explosive gas. Otherwise, it may cause mild injury due to the explosion.



Never disassemble, modify, or repair the product or touch any of the internal parts. Otherwise, it may cause mild electric shock, fire, and equipment failure.



This equipment is an open processing controller. Do not use it in a control cabinet where fire may occur. When using more than 2 open-circuit switches, please turn off all switches before repair inspection, so that the product is in a power-off state.



If the output relays are used past their life expectancy, contact fusing or burning may occasionally occur. Always consider the application conditions and use the output relays within their rated load and electrical life expectancy. The life expectancy of output relays varies considerably with the output load and switching conditions.



## ■ Main features

---

### Display easy to read, powerful, stable performance, friendly docking industrial internet

- DIN 48×48mm, DIN72\*72mm, DIN48\*96mm standard size, adopting a color LCD display screen, the white font is easy to read from a long distance, and the side illuminated backlight is paired with an advanced LCD display screen, resulting in a soft and clear display effect.
- The ultra-thin panel and large screen LCD are paired with a new trend industrial aesthetic shell, giving a more advanced feel.
- Plastic handle waterproof button, the surface of the button is sturdy and wear-resistant, and the operating feel is clear and smooth.
- DIN48x48mm Model the built-in waterproof sealing ring and the external installation of waterproof sealing ring can achieve good waterproof performance.
- Ultra short body, the depth of the body behind the DIN48 × 48mm panel is only 65mm, and the depth of the body behind the DIN72 × 72mm and 48 × 96mm panels is only 60mm.
- The prescaling function (signal and display ratio) has a flexible and wide range, with 0.00001~99999.9 being freely set, up to 5 decimal places, allowing for finer scales when used as a length counter.
- Both low-speed signals and high-speed signals can accurately measure. The maximum counting speed is 10kHz, which can cope with the application scenario of high pulse digital encoders.
- Powerful function, a variety of input mode and output mode can be set to meet the different application requirements.
- There are two models available, T6□C-1P 1-stage preset counter, and T6□C-2P 2-stage preset counter. The T6□C-2P covers multiple functional models: accumulated indicator counter, 1-stage preset counter, 2-stage preset counter, total+ preset counter, batch counter, dual counter, by setting parameters, the required functional models can be obtained.
- Supports RS485 communication interface, adopts the internationally recognized MODBUS-RTU communication protocol, and is friendly connection to the industrial internet.
- Equipped with power outage memory data storage function.
- Very strong anti-interference performance, accurate and reliable counting.
- NPN/PNP input signals can be selectable settings.

## ■ Technical reference

Models	T6□C-1P□-□	T6□C-2P□-□
Functional categories	1-stage preset counter	2-stage preset counter (Covers multiple functional models: accumulated indicator counter, 1-stage preset counter, 2-stage preset counter, total+preset counter, batch counter, dual counter)
External dimension (mm)	48(high)×48(wide)×65(depth) /72(high)×72(wide)×60(depth) /48(high)×96(wide)×60(depth)	
Hole size (mm)	45(high)×45(wide) /68(high)×68(wide) /45(high)×92(wide)	
Power supply	AC100~240V 50/60Hz or AC/DC12~24V (The model suffix has "-D" is 12~24V, and the model suffix does not have "-D" is 100~240V)	
Permissible voltage range	85~110%	
Power consumption	About 5VA (AC240V), about 3.2 VA (DC24V)	
Display mode	Color LCD display (count value white light, set value green light, indicator light orange light)	
Display Range	-99999~999999 (-5~6 digits)	
Prescaling function	Yes (0.00001~99999.9 can be freely set)	
Decimal point adjustment	Yes (right most 5 digits)	
Counting speed	5Hz, 30Hz, 1KHz, 10KHz (selectable settings)	
Input signal	CP1, CP2, RESET1	CP1, CP2, RESET1, RESET2
Input mode	No-voltage (NPN) input/voltage (PNP) input (switchable) No-voltage inputs: ON impedance: 1KΩ max (Leakage current: 12mA at 0Ω) ON residual voltage: 3V max OFF impedance: 100KΩ min Voltage input: High (logic) level: 4.5 to 30VDC Low (logic) level: 0 to 2VDC (Input resistance: approx 4.7KΩ)	
Input Mode	UP (Increment ), DOWN (decrement), increment/decrement UP/DOWN-A (command input), UP/DOWN-B (individual inputs), or UP/DOWN-C (quadrature inputs)	
Output mode	N, F, C, R, K-1, P, Q, A, K-2, D, L	N, F, C, R, K-1, P, Q, A, K-2, D, L, H
Reset mode	Manual reset, external signal reset, automatic reset (depending on output mode)	
External reset minimum signal	1ms or 20ms	
Automatic reset time	0.01~9999.99 seconds	
Control output	1-way relay output (standard configuration), Contact capacity: 3A/AC250V resistive load	2-way relay output (standard), contact capacity: 3A/AC250V resistive load

	Customizable 1-way transistor output: NPN open collector output	Customizable 2-way transistor output: NPN open-circuit collector output
	Customizable 1-way SSR drive voltage (DC12V 100mA) output	Customizable 2-way SSR drive voltage (DC12V 100mA) output
Auxiliary power output	12VDC $\pm$ 10% 100mA Max	
Communication function	RS485 communication interface, Modbus-RTU communication protocol (Only models with S are equipped with this feature)	
Communication protocol	Modbus-RTU communication protocol	
Insulation withstand voltage	AC2000V 50/60Hz 1min	
Usage environment	Temperature -10~+55°C (not freezing or exposed), humidity: 25~85% RH	

## ■ Model definition

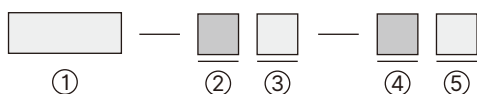

①	②	③	④	⑤	Description
Models	Category	Communication function	Power supply	Control output	
T6GC					DIN48×48mm High performance counter
T6DC					DIN72×72mm High performance counter
T6FC					DIN48×96mm High performance counter
	1P				1-stage preset counter
	2P				2-stage preset counter
		N			No communication
		S			With RS485 communication port
			N or Not to write		Power Supply 100~240V AC
			D		Power Supply 12~24V AC/DC
				N or Not to write	Relay control output
				T	Transistor control output
				Q	SSR drive voltage output



## ■ Panel description

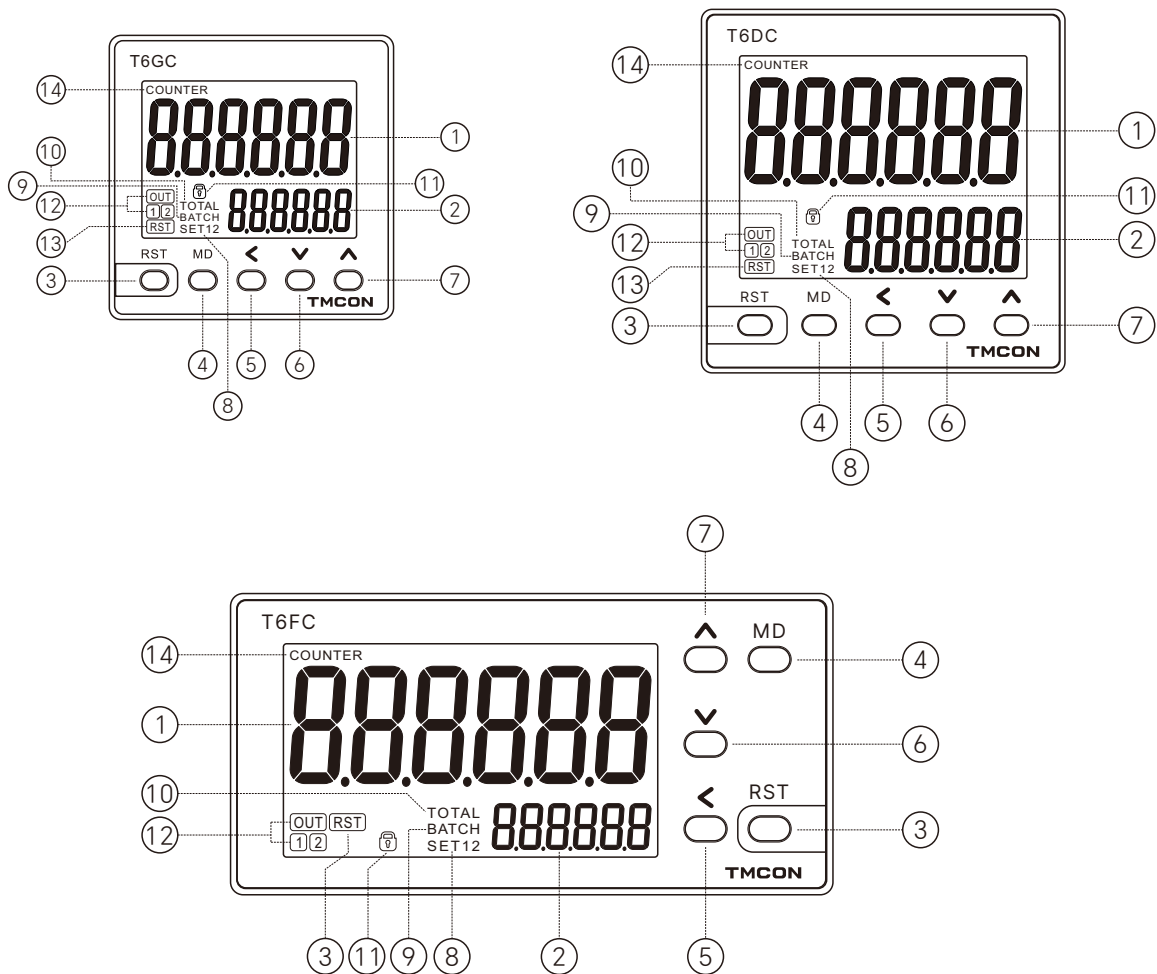

- |                     |   |
|---------------------|---|
| ① Count value       | ⑧ Settings 1, 2 indicator                                       |
| ② Setting value     | ⑨ Batch counter indicator                                       |
| ③ Reset key         | ⑩ Total counter indic   |
| ④ Mode key          | ⑪ Key protect indicator   |
| ⑤ Data shift key    | ⑫ Control Output Indicator<br>OUT (T6□C-1P)<br>OUT1,2 (T6□C-2P) |
| ⑥ Data decrease key | ⑬ Reset indicator   |
| ⑦ Data increase key | ⑭ Counter   |

# Function Setting Mode

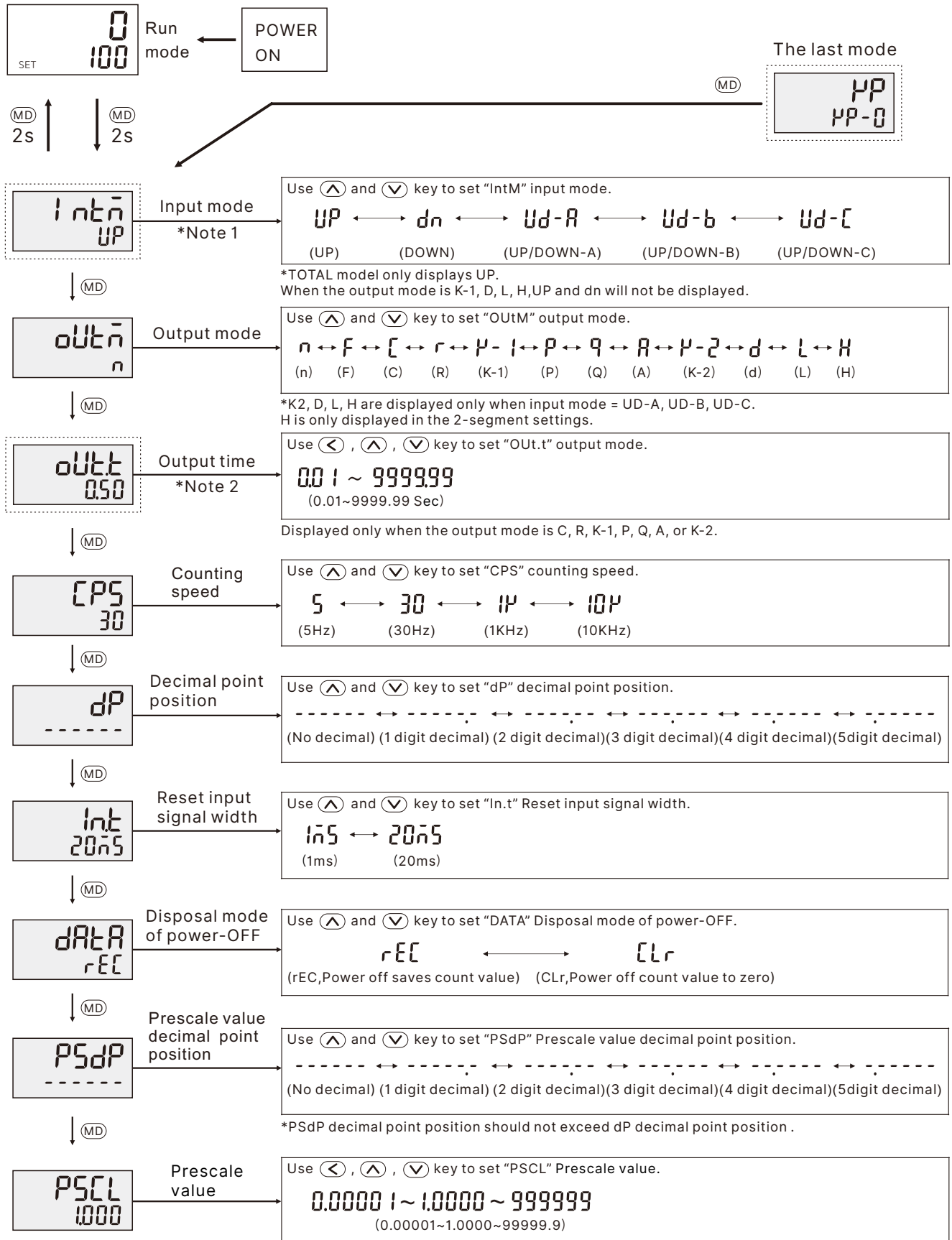

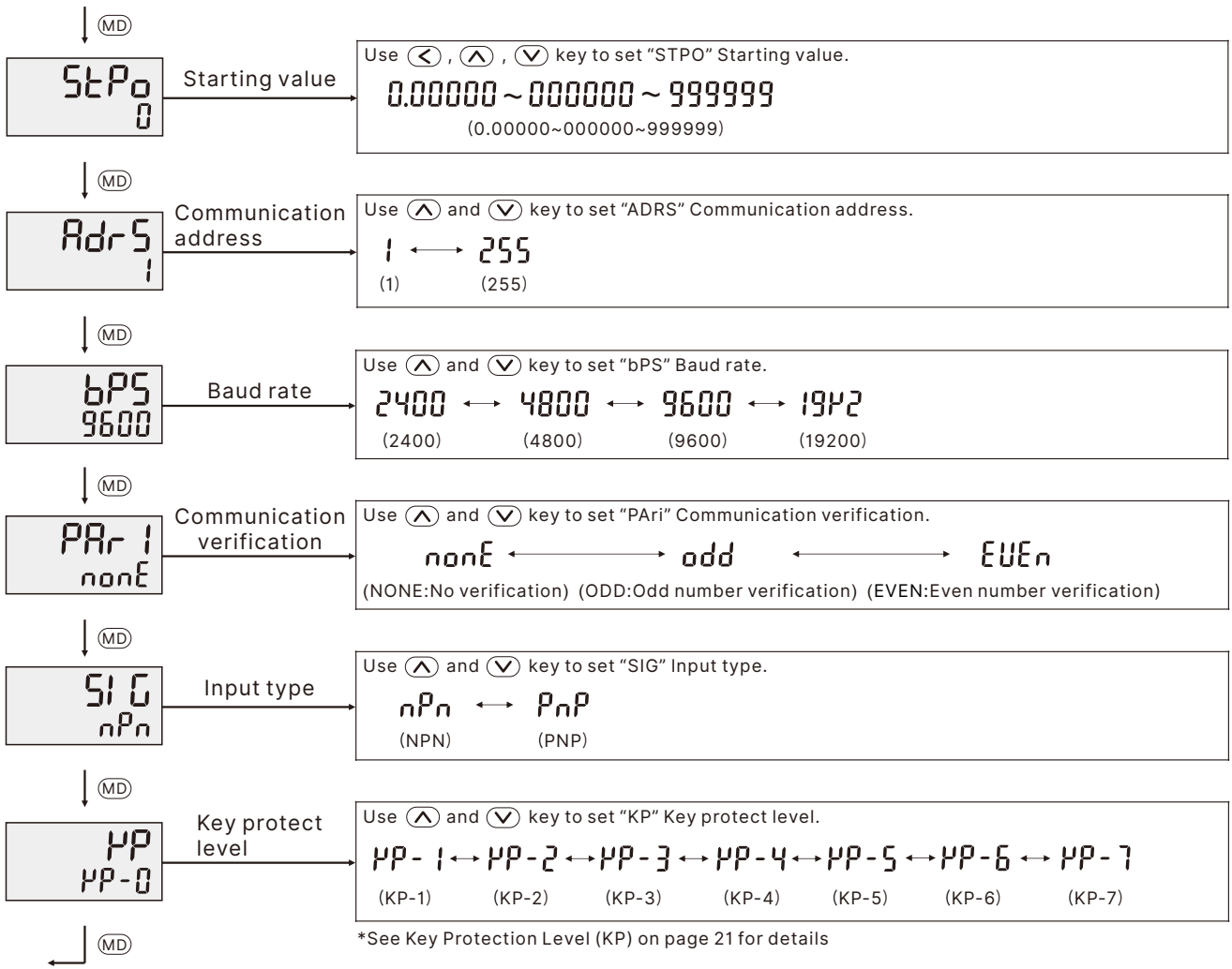

KP This is the last mode, pressing the  $\text{MD}$  key will loop to the first mode at the beginning.

Note 1:

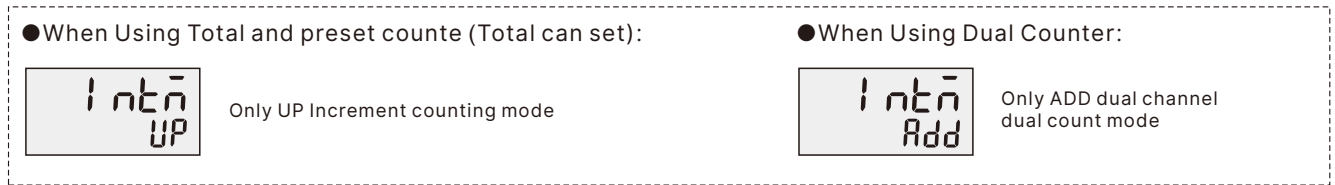

Note 2:

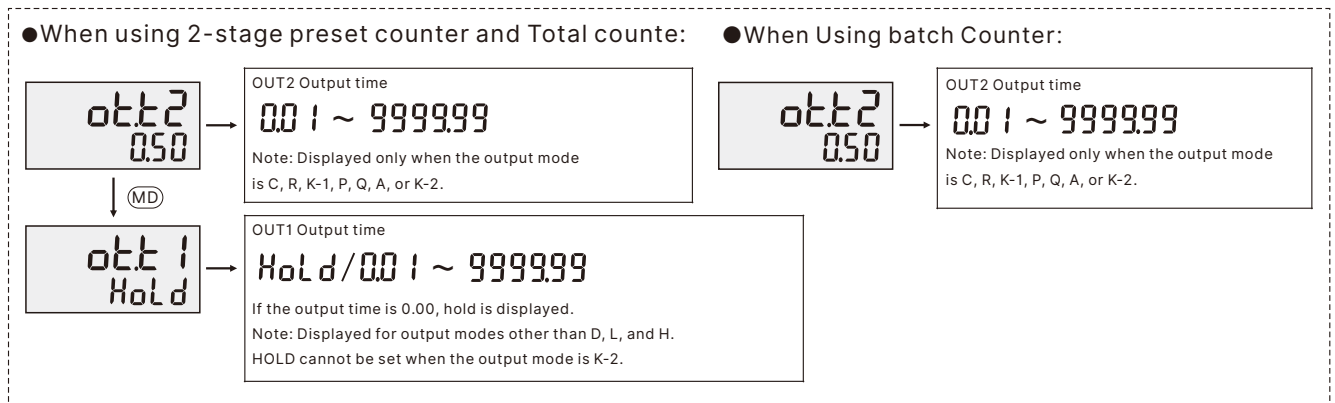

## ■ Configuration selection mode (Only T6□C-2P has this function)

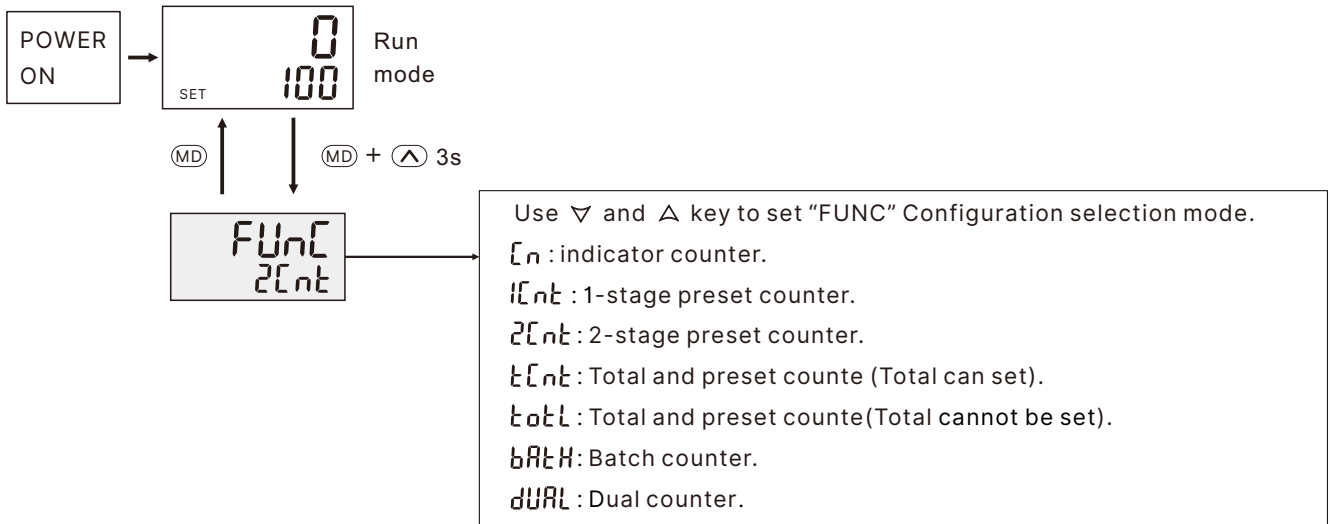

# ■ Operation in Run Mode

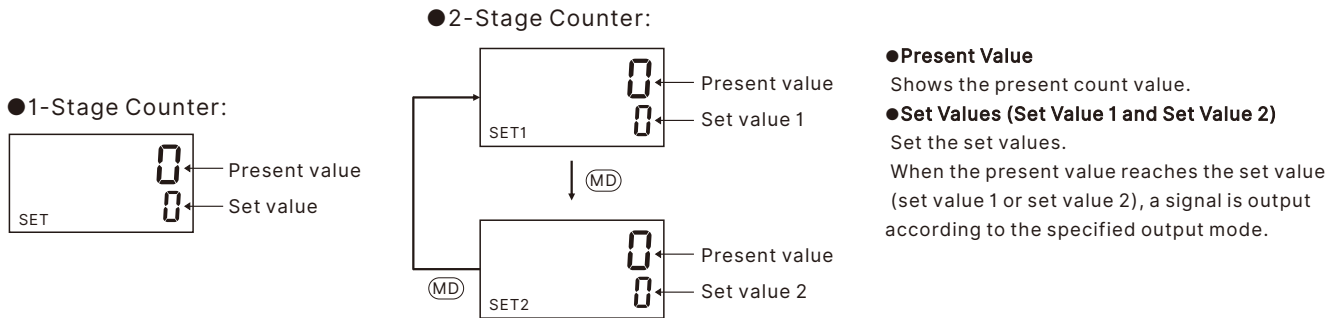

●Total and preset count (Total can set):

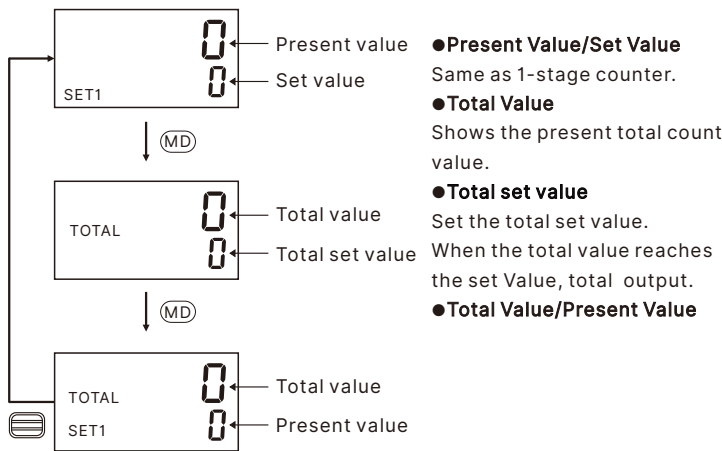

●Total and preset count (Total cannot be set):

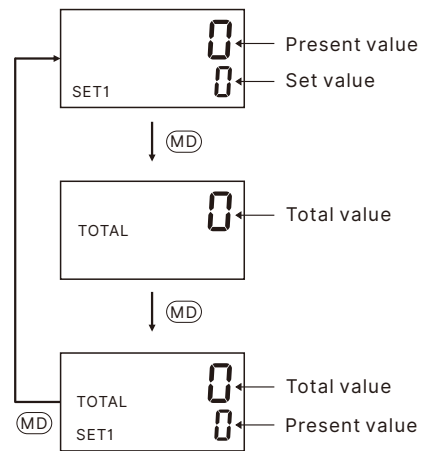

●Batch Counter:

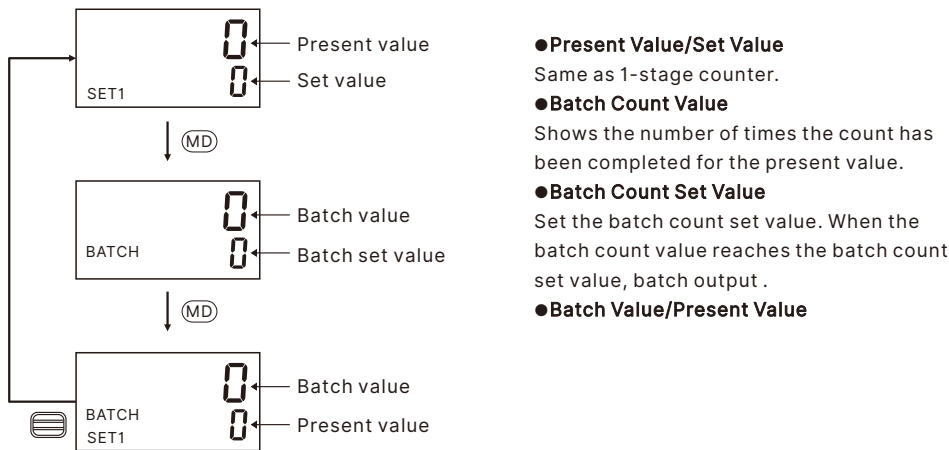

●Dual Counter:

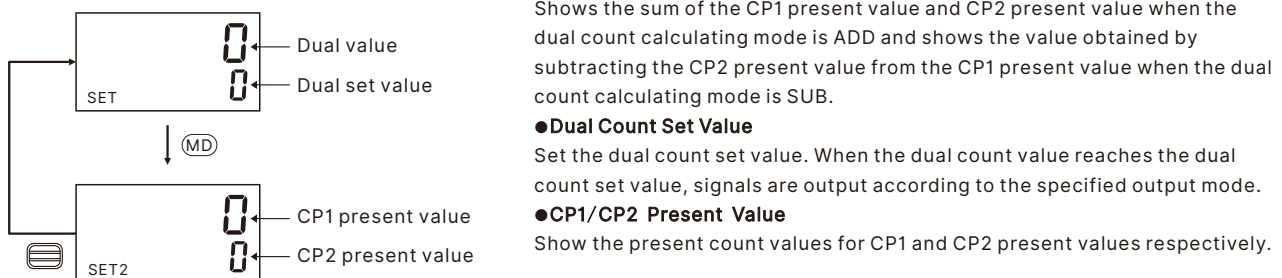

# Input Modes and Present Value

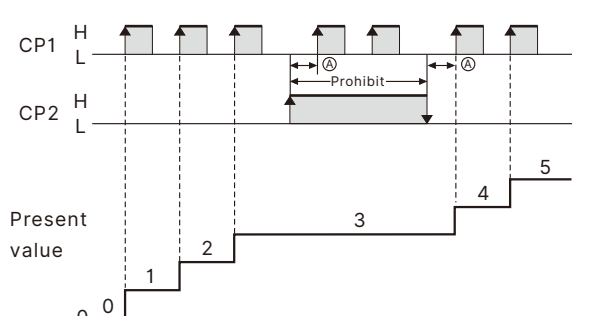
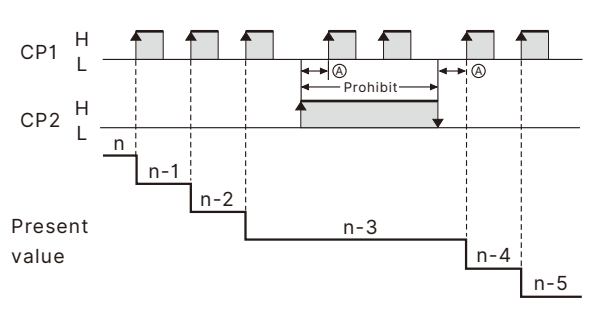
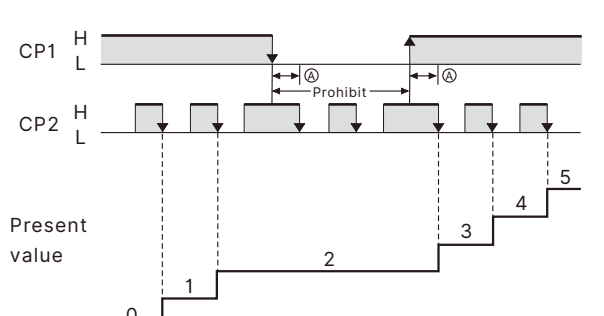
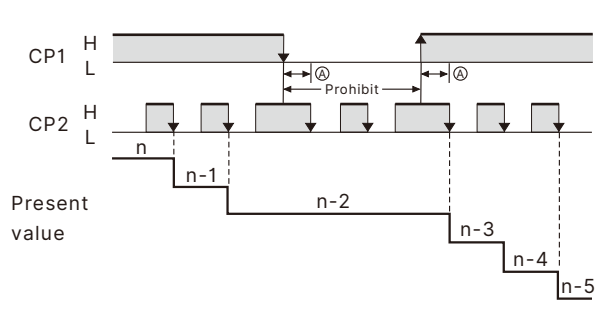
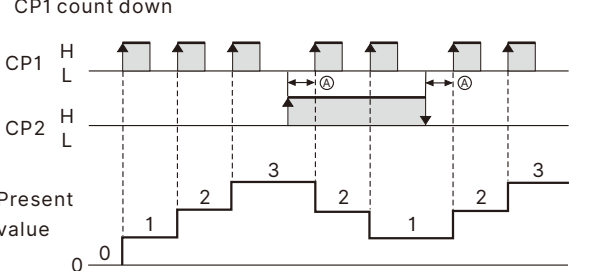
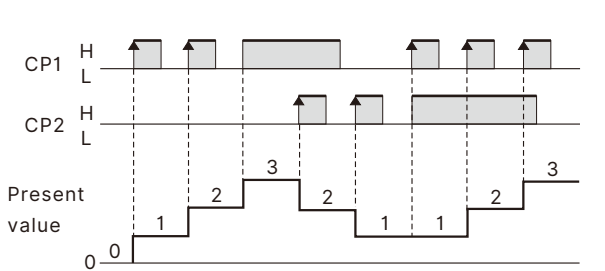
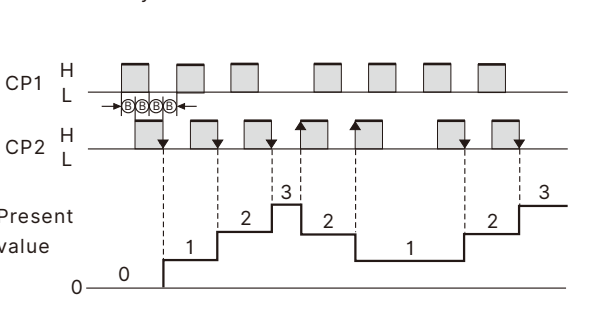
UP (Increment) Mode	DOWN (Decrement) Mode									
<p>CP1: Count input; CP2: Prohibit (gate) input</p>  <p>Present value</p> <p>① must be greater than the minimum signal width. (See note 2.)</p>	<p>CP1: Count input; CP2: Prohibit (gate) input</p>  <p>Present value</p> <p>① must be greater than the minimum signal width. (See note 2.)</p>									
<p>CP1: Prohibit (gate) input; CP2: Count input</p>  <p>Present value</p> <p>① must be greater than the minimum signal width. (See note 2.)</p>	<p>CP1: Prohibit (gate) input; CP2: Present value</p>  <p>Present value</p> <p>① must be greater than the minimum signal width. (See note 2.)</p>									
UP/DOWN A Command Input Mode	UP/DOWN B Individual Input Mode									
<p>CP2 did not enter CP1 plus count, the CP2 input is valid CP1 count down</p>  <p>Present value</p> <p>① must be greater than the minimum signal width. (See note 2.)</p>	<p>input CP1 UP count, input CP2 count down</p>  <p>Present value</p>									
UP/DOWN C Quadrature Input Mode	<p>Note: 1. If the configuration selection is set to dual counter, CP1 and CP2 input will operate in the same way as the count input (CP1) of UP (increment) mode.</p> <p>2. ① must be greater than the minimum signal width and ② must be at least 1/2 the minimum signal width. If they are less, a count error of ±1 may occur.</p> <p>Minimum signal width: 100ms (when maximum counting speed=5Hz)          16.7ms (when maximum counting speed=30Hz)          500μs (when maximum counting speed=1KHz)          100μs (when maximum counting speed=5KHz)</p> <p>3. Counting starts when the CP1 is turned ON after turning ON the power.</p> <p>4. The meaning of the H and L symbols in the tables is explained below.</p> <table border="1" data-bbox="821 1937 1428 2072"> <thead> <tr> <th>Input method Symbol</th> <th>No-voltage input (NPN input)</th> <th>Voltage input (PNP input)</th> </tr> </thead> <tbody> <tr> <td>H</td> <td>Short-circuit</td> <td>DC4.5~30V</td> </tr> <tr> <td>L</td> <td>Open</td> <td>DC0~2V</td> </tr> </tbody> </table>	Input method Symbol	No-voltage input (NPN input)	Voltage input (PNP input)	H	Short-circuit	DC4.5~30V	L	Open	DC0~2V
Input method Symbol	No-voltage input (NPN input)	Voltage input (PNP input)								
H	Short-circuit	DC4.5~30V								
L	Open	DC0~2V								
<p>Automatically determine the forward or reverse</p>  <p>Present value</p> <p>② must be at least 1/2 the minimum signal width. (See note 2.)</p>										

# Input/Output Mode Settings

When using T6□C-1P model is used, the "OUT1 output" is ignored and the "OUT2 output" is regarded as the "OUT" action only. When using T6□C-2P model is used as a 1-stage counter, total and presetcounter (Total cannot be set), or dual counter, OUT1 and OUT2 will be turned on and off at the same time.

One-shot output from OUT1

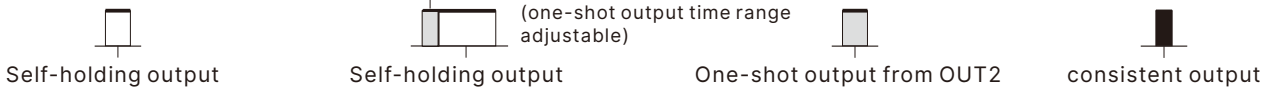

Output mode	Input mode			Operation after count completion
	UP	DOWN	U/D-A, B, C	
N				The outputs and present value display are held until reset/reset 1 is input.
F				The present value display continues to increase/decrease. The outputs are held until reset/reset 1 is input.
C				As soon as the count reaches SV, the present value display returns to the reset start status. The present value display does not show the present value upon countup. The outputs repeat oneshot operation. OUT1 self-holding output turns OFF after the OUT2 one-shot output time. The OUT1 one-shot output time is independent of OUT2.
R				The present value display returns to the reset start status after the one-shot output time. The outputs repeat oneshot operation. OUT1 self-holding output turns OFF after the OUT2 one-shot output time. The OUT1 one-shot output time is independent of OUT2.

Output mode	Input mode			Operation after count completion
	UP	DOWN	U/D-A, B, C	
K-1				<p>The present value display continues to increase/decrease. OUT1 self-holding output turns OFF after the OUT2 one-shot output time. The OUT1 one-shot output time is independent of OUT2.</p>
P				<p>The present value display does not change during the one-shot output time period, but the actual count returns to the reset start status. The output will return to one-shot mode. The outputs repeat one-shot operation. OUT1 self-holding output turns OFF after the OUT2 one-shot output time. The OUT1 one-shot output time is independent of OUT2.</p>
Q				<p>The present value continues to increase/decrease for the oneshot output time, but returns to the reset start status after the one-shot output time has elapsed. The outputs repeat one-shot operation. OUT1 self-holding output turns OFF after the OUT2 one-shot output time. The OUT1 one-shot output time is independent of OUT2.</p>
A				<p>The present value display and OUT1 self-holding output is held until reset/reset 1 is input. OUT1 and OUT2 are independent.</p>

Output mode	Input mode U/D-A, B, C	Operation after count completion
K		<p>The display continues to increase/decrease until the overflow or underflow value is reached. One-shot output only.</p>
D		<p>The display continues to increase/decrease until the overflow or underflow value is reached. The outputs are ON while the count is equal.</p>
L		<p>The display continues to increase/decrease until the overflow or underflow value is reached. OUT1 is held while the present value is less than or equal to set value 1. OUT2 is held while the present value is greater than or equal to set value 2.</p>
H		<p>The display continues to increase/decrease until the overflow or underflow value is reached. OUT1 is held while the present value is greater than or equal to set value 1. OUT2 is held while the present value is greater than or equal to set value 2. * H mode is available only when using a model as a 2-stage counter.</p>

●Total and Preset Counter Operation(Total cannot be set)

When FUnC=tCnt, has a total counter, separate from the 1-stage preset counter, for counting the total accumulated value.

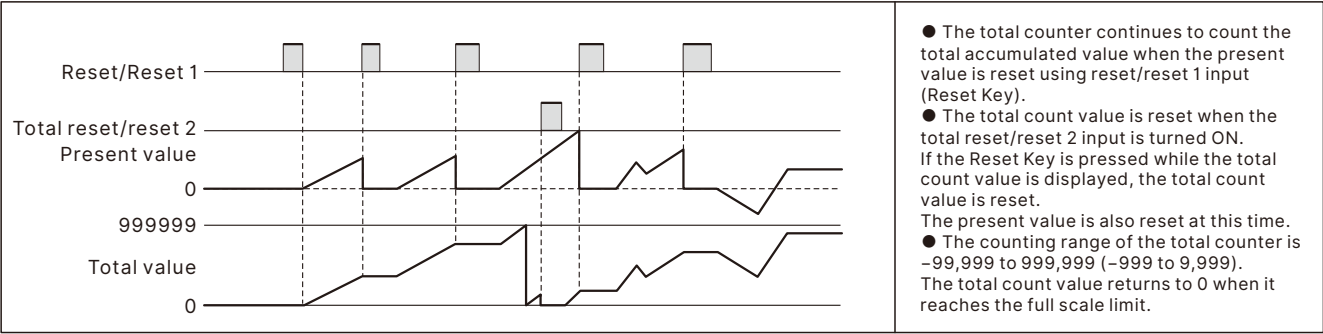

●Total and Preset Counter (Total set)

When FUnC=totAL, has a with set value total counter, separate from the 1-stage preset counter, for counting the total accumulated value and total control output.

Principle: each to the total amount of set value OUT1 is One-shot output (Output mode C), while the cumulative total no stop until it reaches Total Count Value OUT2 output. (Total output modes N, F, C, the R can be set). Can replace the two preset counter.

- The total counter continues to count the total accumulated value when the present value is reset using reset input(reset key).
- The total count value is reset when the total reset input is turned ON. If the reset key is pressed while the total count value is displayed, the total count value is reset. The present value is also reset at this time.

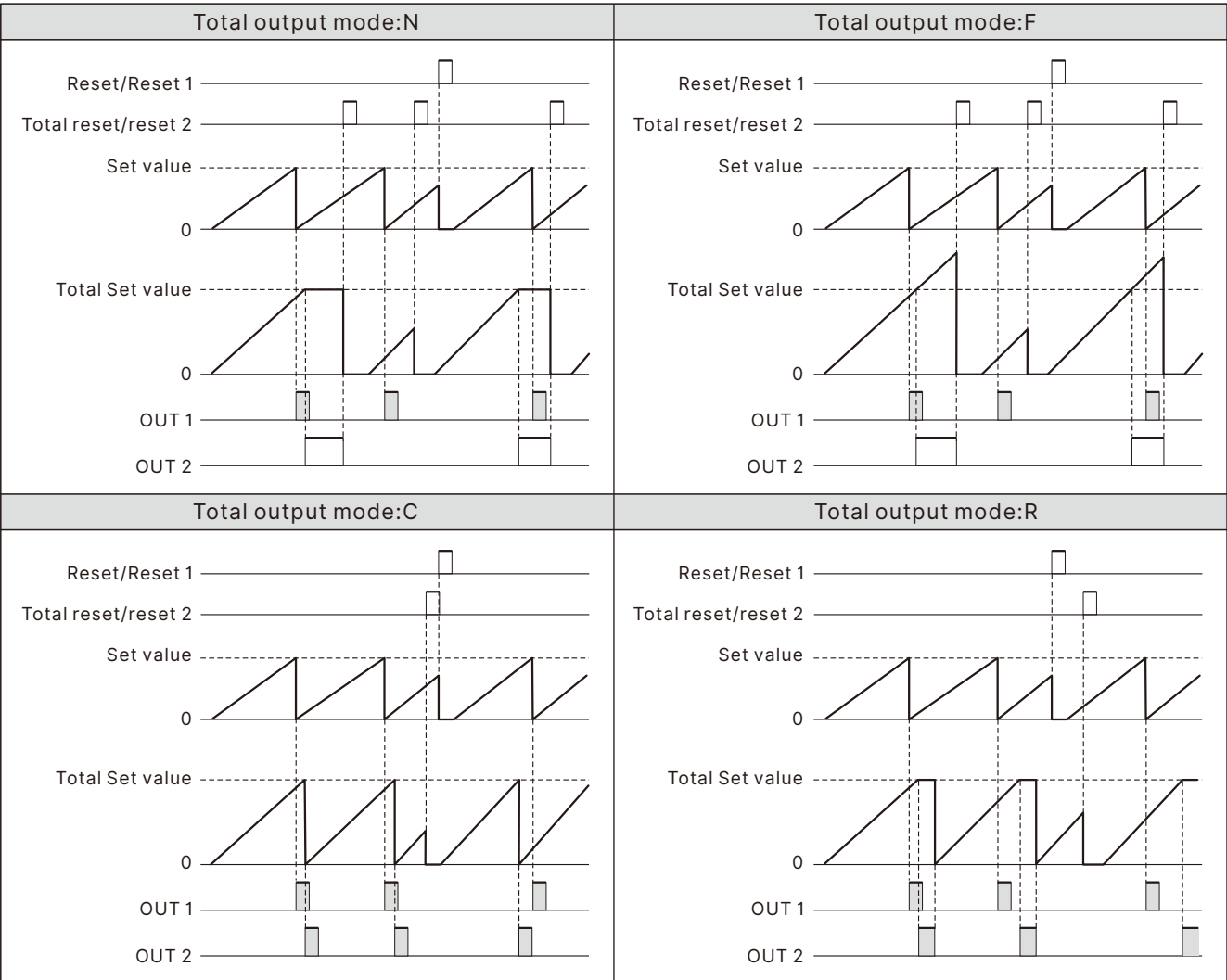

### ●Batch Counter Operation

When FUnC=BAtH, has a batch counter, separate from the 1-stage preset counter, for counting the number of times the count has been completed.

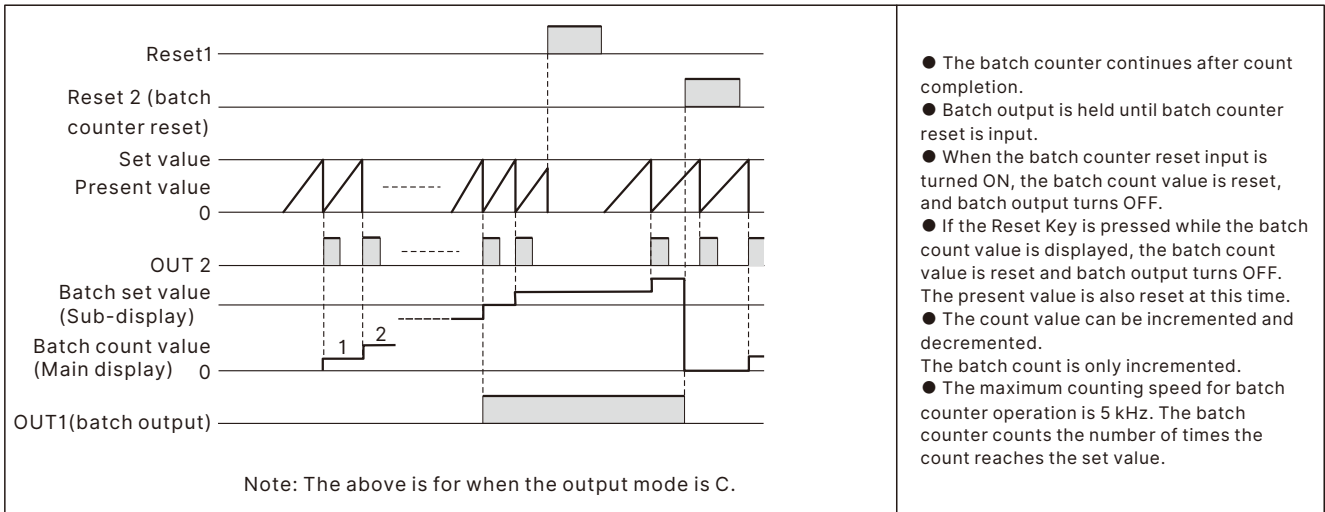

- The batch counter continues after count completion.
- Batch output is held until batch counter reset is input.
- When the batch counter reset input is turned ON, the batch count value is reset, and batch output turns OFF.
- If the Reset Key is pressed while the batch count value is displayed, the batch count value is reset and batch output turns OFF. The present value is also reset at this time.
- The count value can be incremented and decremented.
- The batch count is only incremented.
- The maximum counting speed for batch counter operation is 5 kHz. The batch counter counts the number of times the count reaches the set value.

\*If the batch count set value is changed from a value that is greater than the batch count value to one that is less, batch output will turn ON.  
After batch output turns on, the on state will be held even if the batch count set value is changed to a value greater than the batch count value.

### ●Dual Counter Operation

Using the dual counter allows the count from 2 inputs to be added or subtracted and the result displayed. It is possible to specify a set value for which output turns ON when the set value matches the added or subtracted result.

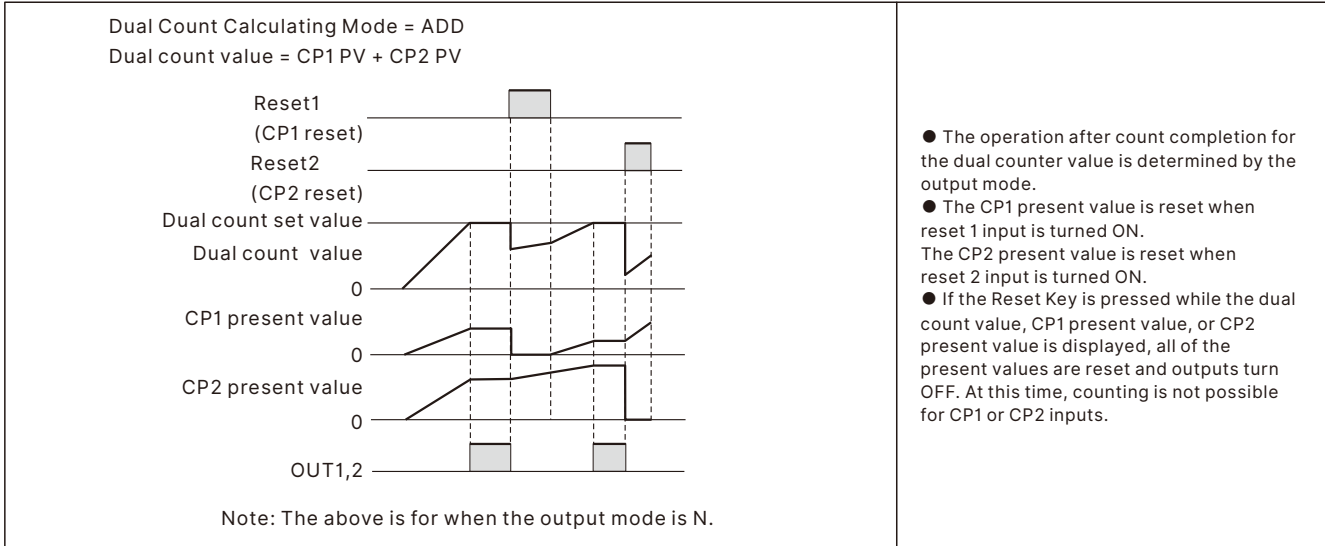

- The operation after count completion for the dual counter value is determined by the output mode.
- The CP1 present value is reset when reset 1 input is turned ON. The CP2 present value is reset when reset 2 input is turned ON.
- If the Reset Key is pressed while the dual count value, CP1 present value, or CP2 present value is displayed, all of the present values are reset and outputs turn OFF. At this time, counting is not possible for CP1 or CP2 inputs.

## ■ Reset Function List

Function	1-stage/2-stage counter	Total and preset counter		Batch counter		Dual counter	
		Present value/set value	Total count value/Total Set value	Present value/set value	Batch count value/batch count set value	Dual count value/dual count set value	CP1 present value/CP2 present value
Screen displayed in run mode	Present value/set value (1, 2)	Present value/set value	Total count value/Total Set value	Present value/set value	Batch count value/batch count set value	Dual count value/dual count set value	CP1 present value/CP2 present value
Reset/reset 1	Present value and output reset	Present value and output reset		Present value and output reset		Only the CP1 present value is reset	
Total reset/reset 2	No effect	Only the total count value is reset/total output		Batch count value and batch output reset		Only the CP2 present value is reset	
Reset key	Present value and output reset	Present value and output reset	Present value, total count value, output reset and total output reset	Present value and output reset.	Present value, batch count value, output and batch output reset	CP1 present value, CP2 present value, dual count value, and output reset.	

# ■ Wiring diagram

## • T6GC

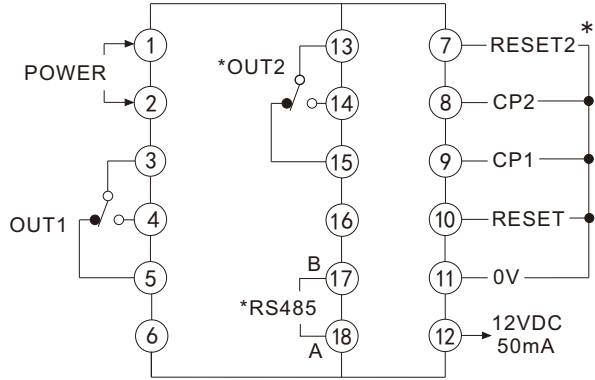

## • T6DC

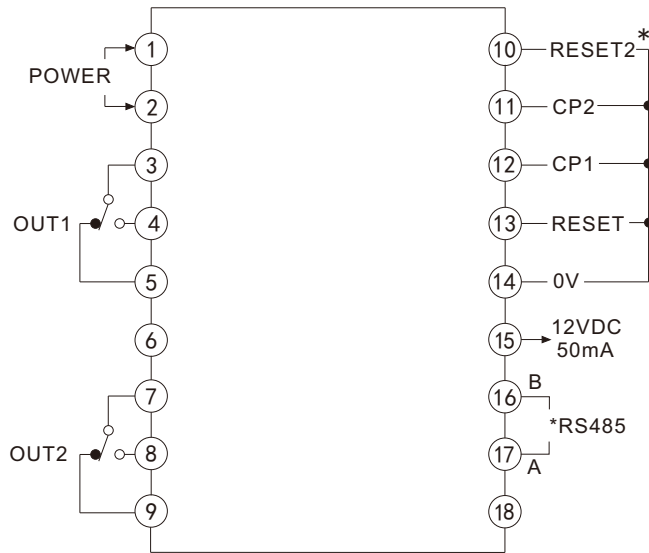

## • T6FC

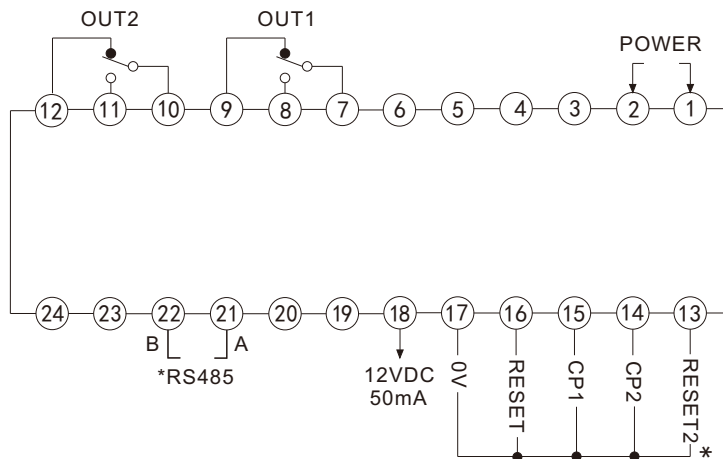

\*Only models with this feature will have this feature port.

## Signal input connection diagram

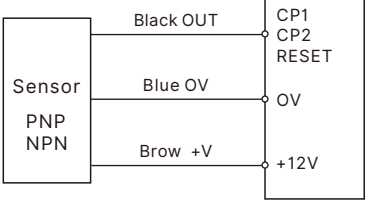
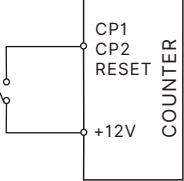
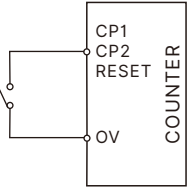
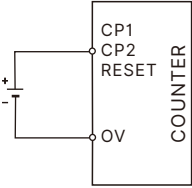
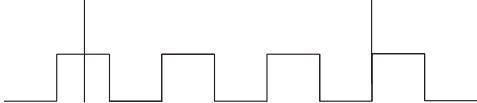
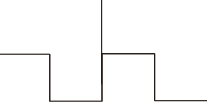
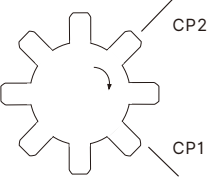
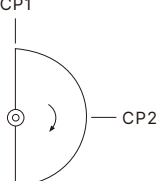
<p>●Sensor input:</p> 	<p>●Contact Input:</p>  <p style="text-align: right;">Input signal is set to PNP</p>
<p>●Contact Input:</p>  <p style="text-align: right;">Input signal is set to NPN</p>	<p>●DC voltage pulse signal input:</p>  <p style="text-align: right;">1:Active-high internal set PNP 2:Active-Low internal set NPN</p>
<p>●The UP / DOWN-C output mode of the sensor installation method: <span style="float: right;">*CP1 and CP2 ready position by 90 °</span></p> <div style="display: flex; justify-content: space-around; align-items: flex-start;"> <div style="text-align: center;"> <p>The CP1 sensor installation location</p>  </div> <div style="text-align: center;"> <p>The CP2 sensor installation location</p>  </div> <div style="text-align: center;">  </div> <div style="text-align: center;">  </div> </div> <p>Reversible UD-C pattern can automatically recognize forward (UP count) and reverse (DOWN count) . In order to realize reversible UD-C mode, two sensors need to be installed, and the position of the sensors should be installed as shown in the figure (the installation phase difference of the two sensors is 90 degrees). Rotary encoder can also be used, whose A and B phases are connected to CP1 and CP2 of the counter respectively.</p>	

## ■ Explanation of Functions

### ● Counting Speed (CPS)

Set the maximum counting speed (5 Hz/30 Hz/1 kHz/5 kHz) for CP1 and CP2 inputs together.

If contacts are used for input signals, set the counting speed to 30 Hz.

Processing to eliminate chattering is performed for this setting.

### ● Reset Input Signal Width (IN.t)

Set the reset input signal width (20 ms/1 ms) for reset/reset 1 and total reset/reset 2 inputs together.

If contacts are used for the input signal, set the input signal width to 20 ms. Processing to eliminate chattering is performed for this setting.

### ● Decimal Point Position (dp)

Decide the decimal point position for the present value, CP1/CP2 present values, set value (SV1, SV2), total count value, and dual count set value.

### ● Input mode, output mode, output time (automatic reset time)

See the relationship between input mode and count and the relationship between input and output modes and actions.

### ● Prescale value decimal point (PSDP)

Determine the decimal point position of the PSCL prescale value. The decimal point position of the PSDP cannot exceed the decimal point position of the DP. A maximum of 5 digits of decimal point can be achieved.

### ● Prescale Value (PSCL)

Pulses input to the counter are converted according to the specified prescale value. (Setting range: 0.001~999.9)

Example: To display the feed distance for systems that output 25 pulses for a feed length of 0.5 m in the form

□□.□□ m:

1. Set the decimal point position to 2 decimal places.

2. Set the prescale value to 0.02 ( $0.5 \div 25$ ).

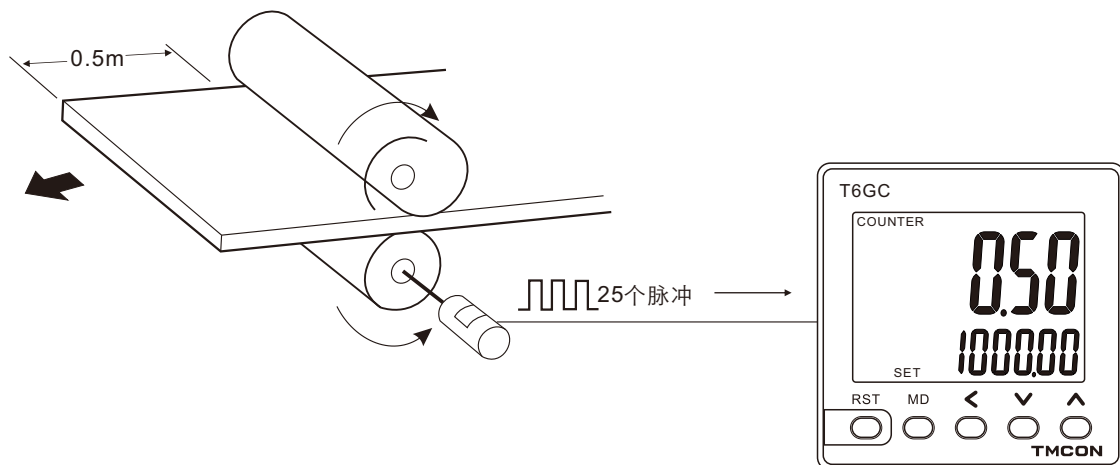

This example realizes that 1 pulse represents 0.02 display value and 25 pulse counters display 0.5.

### ● Observe the following points when setting a prescale value.

Set the set value to a value less than (Maximum count value - Prescale value).

Example: If the prescale value is 1.25 and the counting range is 0.00 to 99.99, set the set value to a value less than  $98.74 (= 99.99 - 1.25)$ .

If the set value is set to a value greater than this, output will not turn ON.

### ● Output will turn ON, however, if a present value overflow occurs (FFFFFF).

● If the default zoom value is set incorrectly, it will lead to counting error. Make sure the settings are correct before use.

● PSCL factory set to 1.000, that is, 1 pulse signal display 1, that is, used as a counter.

### ● NPN/PNP Input Mode (SIG)

Select either NPN input (no-voltage input) or PNP input (voltage input) as the input format. When using a two-wire sensor, select NPN input. The same setting is used for all external inputs.

**●Key Protect Level (KP)**

It is possible to prevent setting errors by prohibiting the use of certain operation keys by specifying the key protect level (KP-1 to KP-7). When KP=1~7,  indicator lights up.

Level	Change mode	Reset key	Set value
KP-0	√	√	√
KP-1	X	√	√
KP-2	√	X	√
KP-3	X	X	√
KP-4	√	√	X
KP-5	X	√	X
KP-6	√	X	X
KP-7	X	X	X

# ■ Size(in mm) and parts and installation description

## ● T4GC

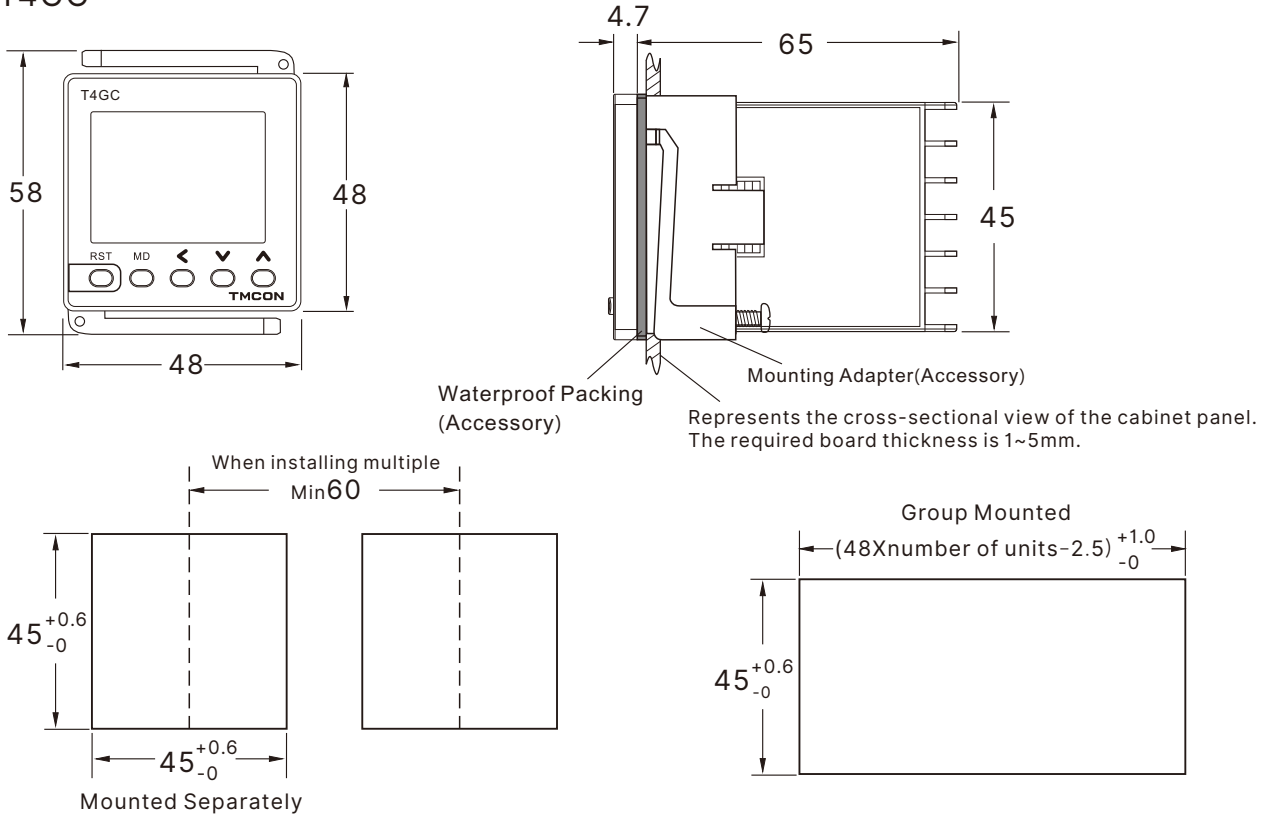

## ● T4DC

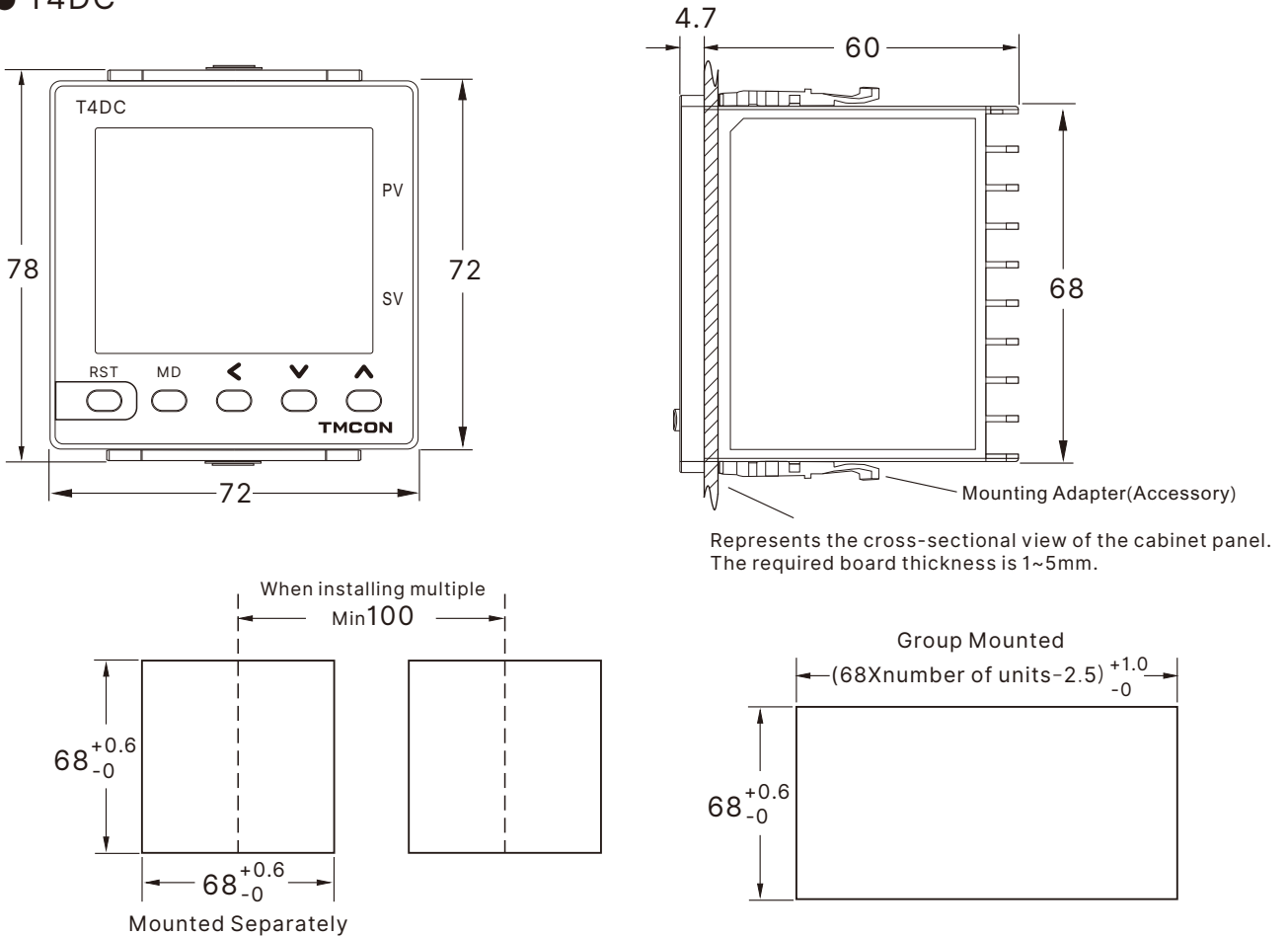

• T6FC

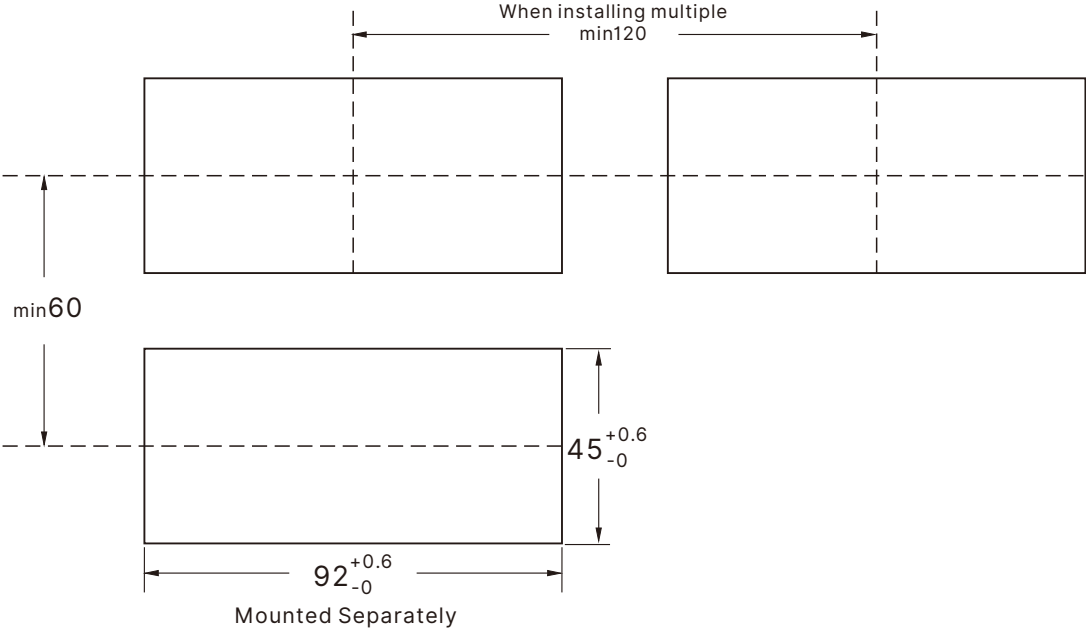
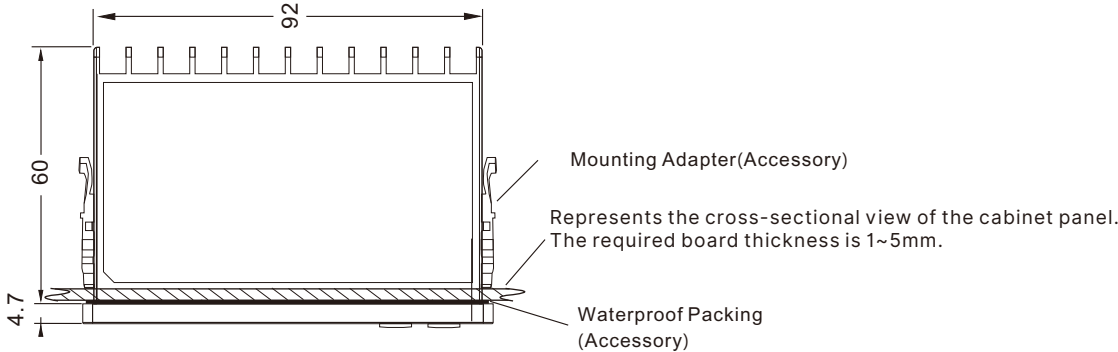
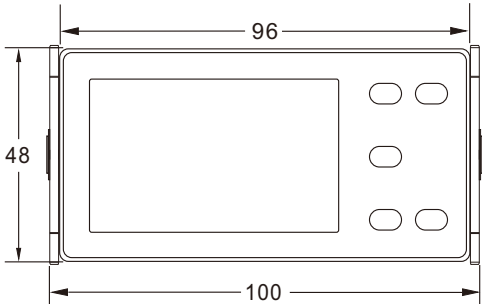

## ■ Note

---

- Before use, make sure that the voltage and connection, to avoid lead to instrument damage due to incorrect wiring.
- Avoid the instrument used in high temperature, flammable, explosive, corrosive, dust, severe shock, humidity, static electricity, oil and other occasions.
- Twist of the instrument signal lines and power lines may cause interference Please try to stay away from these strong electric wires, to conduct an independent wiring, and signal lines as far as possible to shorten the wiring distance.
- Contact signal input, the CPS count rate should be set for low-speed 30Hz, can Prevent switch bounce error count. Reasonable speed settings, you can make the count more accurate.
- Output relay, please do not exceed the switching capacity, according to the rated load, otherwise it would contact burned, such as an external high current relay or contactor exceeds its capacity.

